

OPERATION MANUAL

STOW

A DIVISION OF MULTIQUIP INC.

CUTTER 1 CE SERIES MODEL CD6CE13H18 CONCRETE/ASPHALT SAW (HONDA GX390 GASOLINE ENGINE)

Revision #2 (12/20/07)

To find the latest revision of this
publication, visit our website at:
www.stowmfg.com



THIS MANUAL MUST ACCOMPANY THE EQUIPMENT AT ALL TIMES.

P/N 35440



CALIFORNIA — Proposition 65 Warning

Engine exhaust and some of its constituents, and some dust created by power sanding, sawing, grinding, drilling and other construction activities contains chemicals known to the State of California to cause cancer, birth defects and other reproductive harm.

Some examples of these chemicals are:

- Lead from lead-based paints.
- Crystalline silica from bricks.
- Cement and other masonry products.
- Arsenic and chromium from chemically treated lumber.

Your risk from these exposures varies, depending on how often you do this type of work. To reduce your exposure to these chemicals: **ALWAYS** work in a well ventilated area, and work with approved safety equipment, such as dust masks that are specially designed to filter out microscopic particles.

WARNING



SILICOSIS WARNING

Grinding/cutting/drilling of masonry, concrete, metal and other materials with silica in their composition may give off dust or mists containing crystalline silica. Silica is a basic component of sand, quartz, brick clay, granite and numerous other minerals and rocks. Repeated and/or substantial inhalation of airborne crystalline silica can cause serious or fatal respiratory diseases, including silicosis. In addition, California and some other authorities have listed respirable crystalline silica as a substance known to cause cancer. When cutting such materials, always follow the respiratory precautions mentioned above.

WARNING

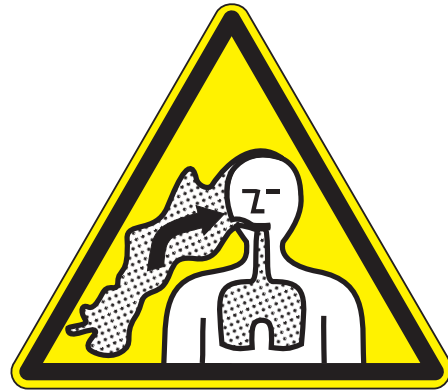

RESPIRATORY HAZARDS

Grinding/cutting/drilling of masonry, concrete, metal and other materials can generate dust, mists and fumes containing chemicals known to cause serious or fatal injury or illness, such as respiratory disease, cancer, birth defects or other reproductive harm. If you are unfamiliar with the risks associated with the particular process and/or material being cut or the composition of the tool being used, review the material safety data sheet and/or consult your employer, the material manufacturer/supplier, governmental agencies such as OSHA and NIOSH and other sources on hazardous materials. California and some other authorities, for instance, have published lists of substances known to cause cancer, reproductive toxicity, or other harmful effects.

Control dust, mist and fumes at the source where possible. In this regard use good work practices and follow the recommendations of the manufacturers or suppliers, OSHA/NIOSH, and occupational and trade associations. Water should be used for dust suppression when wet cutting is feasible. When the hazards from inhalation of dust, mists and fumes cannot be eliminated, the operator and any bystanders should always wear a respirator approved by NIOSH/MSHA for the materials being used.

STOW CUTTER 1 CE SAW — TABLE OF CONTENTS

STOW CUTTER 1 CE SAW

Model CD6CE13H18

| | |
|--|-------|
| Proposition 65 Warning | 2 |
| Silicosis/Respiratory Warnings | 3 |
| Table Of Contents | 4 |
| Safety Message Alert Symbols | 5-6 |
| Rules For Safe Operation | 7-9 |
| Specifications (Saw) | 10 |
| Specifications (Engine) | 11 |
| General Information | 12 |
| Controls & Components | 13 |
| Basic Engine | 14 |
| Preparation/Pre-Inspection | 15-16 |
| Blades | 17 |
| Blade Placement | 18-19 |
| Raise/Lower & Depth Stop | 20 |
| Initial Start-Up | 21-22 |
| Operation | 23-24 |
| Maintenance | 25-26 |
| Optional Water Tank | 27-28 |
| Troubleshooting (Saw) | 29 |
| Troubleshooting (Engine) | 30-31 |
| Terms and Conditions of Sale — Parts | 32 |

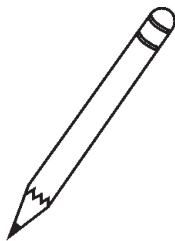
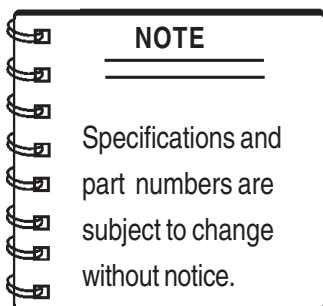

STOW CUTTER 1 CE SAW — SAFETY MESSAGE ALERT SYMBOLS

FOR YOUR SAFETY AND THE SAFETY OF OTHERS!

Safety precautions should be followed at all times when operating this equipment. Failure to read, understand and comply with the Safety Messages and Operating Instructions could result in injury to yourself or others.

NOTE

This Owner's Manual has been developed to provide instructions for the safe and efficient operation of the STOW CUTTER 1 CE SAW. For engine maintenance information, please refer to the engine manufacturers' instructions for data relative to its safe operation.

Before using this CONCRETE/ASPHALT SAW, ensure that the operating individual has read and understands all instructions in this manual.

SAFETY MESSAGE ALERT SYMBOLS

The three (3) Safety Messages shown below will inform you about potential hazards that could injure you or others. The Safety Messages specifically address the level of exposure to the operator, and are preceded by one of three words: **DANGER**, **WARNING**, or **CAUTION**.

DANGER

You **WILL** be **KILLED** or **SERIOUSLY INJURED** if you **DO NOT** follow these directions.

WARNING

You **CAN** be **KILLED** or **SERIOUSLY INJURED** if you **DO NOT** follow these directions.

CAUTION

You **CAN** be **INJURED** if you **DO NOT** follow these directions.

Potential hazards associated with CUTTER 1 CE operation will be referenced with "**Hazard Symbols**" which appear throughout this manual, and will be referenced in conjunction with Safety "**Message Alert Symbols**".

HAZARD SYMBOLS



Lethal Exhaust Gases



Engine exhaust gases contain poisonous carbon monoxide. This gas is colorless and odorless, and can cause death if inhaled. **NEVER** operate this equipment in a confined area or enclosed structure that does not provide ample free flow air.



Guards and Covers In Place

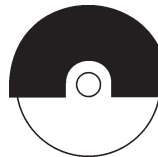

NEVER operate the saw without blade guards and covers in place. Adhere to safety guidelines and applicable local regulations.



Burn Hazards



Engine components can generate extreme heat. To prevent burns, **DO NOT** touch these areas while the engine is running or immediately after operations. **NEVER** operate the engine with heat shields or heat guards removed.



Rotating Parts



NEVER operate equipment with covers, or guards removed. Keep fingers, **hands**, **hair** and **clothing** away from all moving parts to prevent injury.

STOW CUTTER 1 CE SAW — SAFETY MESSAGE ALERT SYMBOLS



Accidental Starting



OFF **ALWAYS** place the engine ON/OFF switch in the **OFF** position, when the saw is not in use.



Respiratory Hazard



ALWAYS wear approved respiratory protection.



Over Speed Conditions



NEVER tamper with the factory settings of the engine governor. Personal injury and damage to the engine or equipment can result if operating in speed ranges above maximum allowable.



Sight and Hearing hazard

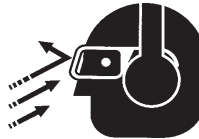

ALWAYS wear approved eye and hearing protection.



Rotating Blade



Rotating blade can cut and crush. Keep hands and feet clear.



Equipment Damage Messages

Other important messages are provided throughout this manual to help prevent damage to your concrete saw, other property, or the surrounding environment.



CAUTION

This **concrete/asphalt saw**, other property, or the surrounding environment could be damaged if you do not follow instructions.

STOW CUTTER 1 CE SAW — RULES FOR SAFE OPERATION

RULES FOR SAFE OPERATION



WARNING

Failure to follow instructions in this manual may lead to serious injury or even death! This equipment is to be operated by trained and qualified personnel only! This equipment is for industrial use only.

The following safety guidelines should always be used when operating the CUTTER 1 CE Saw.

SAFETY

- **DO NOT** operate or service this equipment before you read, understand, and comply with all safety messages in this manual. The manual must be kept available and accessible to the operator.
- This equipment should not be operated by persons under the minimum statutory age limit.
- **NEVER** use this machine for any purpose other than those described in this manual.
- **NEVER** operate the saw without proper protective clothing, shatter-proof glasses, steel-toed boots and other protective devices required for the job.



- **NEVER** use accessories or attachments which are not recommended by the manufacturer for this equipment. Damage to the equipment and/or injury to user may result.
- Manufacturer does not assume responsibility for any accident due to equipment modifications. Unauthorized equipment modification will void all warranties. Any modification which could lead to a change in the original characteristics of the machine should be made only by the manufacturer who shall confirm that the machine is in conformity with appropriate safety regulations.

- **NEVER** operate this equipment when not feeling well due to fatigue, illness or taking medicine.
- **NEVER** operate the saw under the influence of drugs or alcohol.
- Replace nameplate, operation and safety decals when they become difficult to read.
- **ALWAYS** check the saw for loosened hardware such as nuts and bolts before starting.

- **NEVER** touch the hot exhaust manifold, muffler or cylinder. Allow these parts to cool before servicing the saw.



- **High Temperatures** – Allow the engine to cool before adding fuel or performing service and maintenance functions. Contact with **hot!** components can cause serious burns.

- The engine of this saw requires an adequate free flow of cooling air. **NEVER** operate the saw in any enclosed or narrow area where free flow of the air is restricted. If the air flow is restricted it will cause serious damage to the saw's engine and may cause injury to people. Remember the saw's engine gives off **DEADLY** carbon monoxide gas.

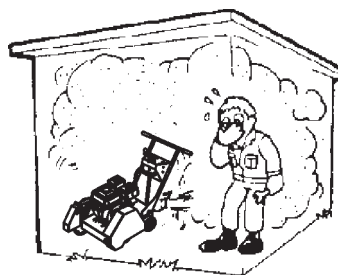

- **ALWAYS** refuel in a well-ventilated area, away from sparks and open flames.

- **ALWAYS** use extreme caution when working with **flammable** liquids. When refueling, **STOP** the engine and allow it to cool.

- **NEVER** operate the saw in an explosive atmosphere where fumes are present, or near combustible materials. An explosion or fire could result in severe **bodily harm or even death**.

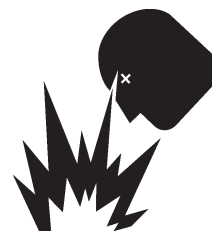

- **NEVER** smoke around or near the machine. Fire or explosion could result from **fuel vapors**, or if fuel is spilled on a **hot!** engine.



- Topping-off to filler port is dangerous, as it tends to spill fuel.
- **NEVER** use fuel as a cleaning agent.

STOW CUTTER 1 CE SAW — RULES FOR SAFE OPERATION

General Safety

- **ALWAYS** read, understand, and follow procedures in Operator's Manual before attempting to operate equipment.
- **ALWAYS** be sure the operator is familiar with proper safety precautions and operating techniques before using the saw.
- **NEVER** leave the machine *unattended* while running.
- Apply the brakes when leaving or when using on a slope.
- Maintain this equipment in a safe operating condition at all times.
- **ALWAYS** stop the engine before servicing, adding fuel and oil.
- **NEVER** run the engine without the air filter. Severe engine damage could occur.
- **ALWAYS** service air cleaner frequently to prevent carburetor malfunction.
- **AVOID** wearing jewelry or loose fitting clothing that may snag on the controls or moving parts, this can cause a serious injury.
- **ALWAYS** keep clear of *rotating* or *moving parts* while the saw is in operation.
- **ALWAYS** store equipment properly when it is not being used. Equipment should be stored in a clean, dry location out of the reach of children.
- **ALWAYS** keep the work area well organized.
- **ALWAYS** Clear the cutting area of any debris, tools, etc. that would constitute a hazard while the saw is in operation.

 **WARNING**

ALWAYS check to make sure that the cutting area is clear before starting the engine.



- Keep all inexperienced and unauthorized people clear of the cutting area when operating the saw.
- Always observe all applicable compulsory regulations relevant to environmental protection, especially fuel storage, the handling of hazardous substances, and the wearing of protective clothing and equipment. Instruct the user as necessary, or, as the user, request this information and training.

Diamond Blade Safety

- Use appropriate steel centered diamond blades manufactured for use on concrete saws. See further blade information on pages 19 to 21.

 **WARNING**

ALWAYS inspect diamond blades before each use. The blade should exhibit no cracks, dings, or flaws in the steel centered core and/or rim. Center (arbor) hole must be undamaged and true.



- Examine blade flanges for damage and excessive wear.
- Ensure the cleanliness of the blade before blade is installed. Blade should fit snugly on the shaft and against the inside/outside blade flanges.
- Ensure the blade is marked with an operating speed greater than the spindle speed of the saw.
- Only cut the material that is specified for the diamond blade. Read the specifications of the diamond blade to ensure the proper tool has been matched to the material being cut. The saw has been engineered for **WET CUTTING**. Ensure a **WET CUTTING** blade is being used and that the water supply system to the blade is properly functioning and being used.
- **ALWAYS** keep blade guards in place. Exposure of the diamond blade must not exceed 180 degrees.
- Ensure that the diamond blade does not come into contact with the ground or surface during transportation. **DO NOT** drop the diamond blade on ground or surface.
- The engine governor is set to permit maximum engine speed in a no-load condition. Do not tamper with the engine governor to increase the speed. Increasing the engine speed could allow the maximum rated spindle speed to be exceeded, creating an unsafe condition.
- Ensure that the blade is mounted for proper operating direction. (See Figure 3, page 15)
- Adhere to the Blade Manufacturer's recommendations on handling, storage, and safe usage of blades.

STOW CUTTER 1 CE SAW — RULES FOR SAFE OPERATION

Saw Transportation Safety

- **DO NOT** use the handle bars and/or front pointer as lifting points.
- **ALWAYS** use ramps capable of supporting the weight of the saw and the operator to load and unload the saw. If the saw must be lifted, always use two people. Never attempt to lift the saw by yourself.
- **NEVER** attempt to tow the untrailerred saw behind a vehicle.
- **DO NOT** use on slopes or on extremely uneven surfaces.
- **NEVER** tip the engine to extreme angles as it may cause oil to gravitate into the cylinder head making the engine start difficult.
- **NEVER** transport the saw to or from the job site with the blade mounted.

EMERGENCIES

- **ALWAYS** know the location of the nearest **fire extinguisher**.



- **ALWAYS** know the location of the nearest **first aid kit**.



- In emergencies **always** know the location of the nearest phone or **keep a phone on the job site**. Also know the phone numbers of the nearest **ambulance, doctor, and fire department**. This information will be invaluable in the case of an emergency.



Machine Operation And Safety Decals

The CUTTER 1 CE saw is equipped with a number of operation and safety decals. (Figure 1) Should any of these decals become unreadable, replacements can be obtained from your dealer.



P/N 35137



P/N 25867

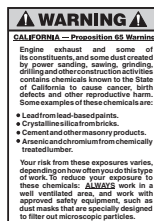

P/N 20525



P/N 23330-001



CONTACT PARTS DEPARTMENT



P/N 13118



P/N 23653-001



P/N 22122-001



P/N 35158



P/N 11092

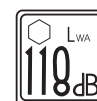

P/N 35167



P/N 36099 (ISO Blue)



P/N 25250-001



P/N 25249-001



P/N 25491



P/N 25678



P/N 22972-003 6.00 LG

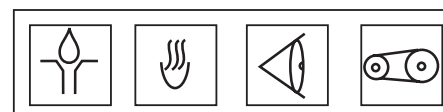

P/N 11246 (Sheet-Intl. Stds)

Figure 1. CUTTER 1 CE Decals

STOW CUTTER 1 CE SAW — SPECIFICATIONS (SAW)

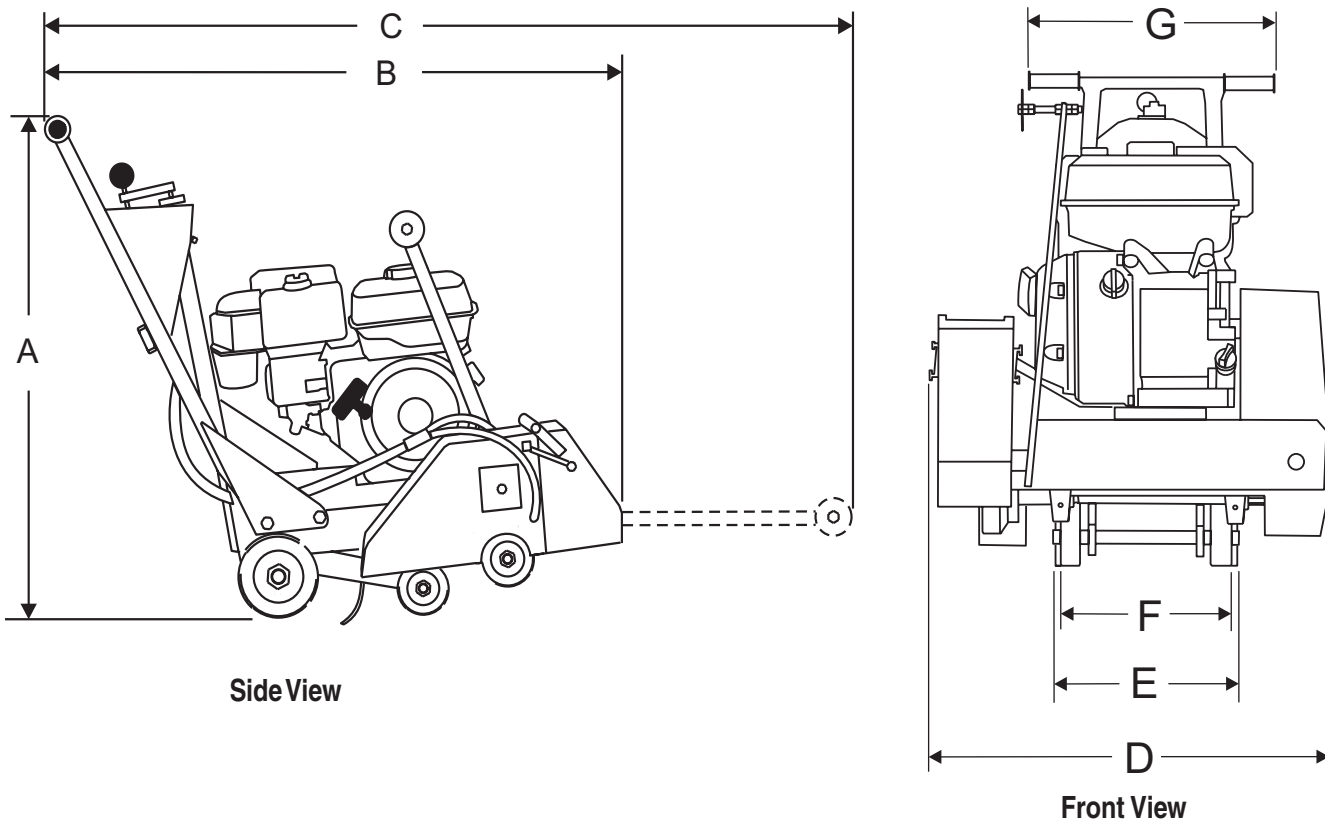

Figure 2. CUTTER 1 CE Dimensions

Table 1. Cutter 1 CE (CD6CE13H18) Specifications

| REFERENCE LETTER | DESCRIPTION | DIMENSION (cm) |
|------------------|--|-----------------------|
| A | Height | 37.0 In. (94 cm) |
| B | Length (Front Pointer Raised) | 32.0 In. (80 cm) |
| C | Maximum Length (Front Pointer Lowered) | 54.5 In. (138 cm) |
| D | Width | 21.5 In. (55 cm) |
| E | Rear Wheel Base | 17.0 In. (40 cm) |
| F | Front Wheel Base | 10.0 In. (25.4 cm) |
| G | Handle Bar Width | 21.5 In. (55 cm) |
| | Maximum Spindle RPM | 2836 RPM |
| | Arbor Size | 1.0" (2.54 cm) |
| | Maximum Cutting Depth | 7.0" (17.78 cm) |
| | Sound Pressure at Operator's Position | 99.8 db |
| | Vibration * | 12.6 ms ⁻² |
| | Maximum Operating Mass | 236 lbs.(107 Kg) |
| | Nominal Mass (without blade or fluids) | 214 Lb. (97 Kg) |

* Vibration (at handle) results with Cutter 1 CE Saw cutting concrete at a depth of 1-1/2 inches (38.1 mm) with an 18" (45.7 cm) blade, FULL THROTTLE.

STOW CUTTER 1 CE SAW — SPECIFICATIONS (ENGINE)

Table 2. Specifications (Engine)

| | | |
|--------------------------|--|--|
| Engine | Model | HONDA GX390K1QWT2/GX390U1QWT2 |
| | Type | Air-cooled 4 stroke, Single Cylinder, OHV, Gasoline Engine |
| | Bore X Stroke | 3.5 in. X 2.5 in. (88 mm x 64 mm) |
| | Displacement | 23.7 cu-in. (389 cc) |
| | Max Output | 12.9 bhp (9.6kW, 13PS) @ 3600 R.P.M. |
| | Fuel Tank Capacity | Approx. 1.72 U.S. Gallons (6.5 Liters) |
| | Fuel | Unleaded Automobile Gasoline 86 Octane or higher |
| | Lube Oil Capacity | 1.16 US qt (1.1 liter) |
| | Speed Control Method | Centrifugal Fly-weight Type |
| | Starting Method | Transistorized Magneto |
| Dimension (L x W x H) | 16.7 x 17.7 X 17.4 in. (425 X 450 X 443 mm) | |
| Dry Net Weight | 63.9 lbs (29 Kg.) | |

STOW CUTTER 1 CE SAW — GENERAL INFORMATION

Intended Use

Operate the CUTTER 1 CE Saw, tools and components in accordance with the manufacturer's instructions. Use of any other tools for stated operation is considered contrary to designated use. The risk of such use lies entirely with the user. The manufacturer cannot be held liable for damages as a result of misuse.

This saw is not intended for dry cutting.

General Information

The STOW CUTTER 1 CE saws are designed for **wet** cutting of **concrete** or **asphalt** utilizing Diamond Blades. These saws have been engineered for general and industrial flat sawing applications. The reinforced steel box frame design adds strength necessary to reduce blade vibrations while cutting. By minimizing blade vibrations the performance of the blade is enhanced and thus the life of the blade is extended.

Heavy-duty front and rear axles, sturdy oversized wheels, and industrial undercarriage assembly ensure accurate tracking and years of reliable use.

Additionally, the general strength-to-weight ratio design of the frame and chassis assembly provides for optimum weight distribution to keep the blade running true in the cut. A rugged spindle bearing assembly ensures minimal flutter and shaft harmonics providing the most advantageous condition for a diamond blade at operating speeds.

The CUTTER 1 CE series saw comes equipped with an 18-inch blade guard and handles Diamond Blades ranging in size from 12-18-inches in diameter.

An ACME thread, manual **raise/lower** assembly easily raises and lowers the blade and locks it into position to ensure a constant depth cut. All CUTTER 1 CE series saws are equipped with a retractable cutting guide, oversized roller bearing wheels, industrial spindle bearings, and a rigid steel frame.

Power Plants

The CUTTER 1 CE saw is classified in the industry as a "low" powered saw. This classification is particularly useful when selecting the proper diamond blade for an application.

The CUTTER 1 CE saw is powered by a HONDA GX-390 air cooled, 4-stroke, single cylinder, OHV gasoline engine rated at 13 HP (9.6 kW) at 3,600 RPM. Blade rotation is V-belt driven. The upper drive (engine) pulley on the output shaft of the engine connects to the lower drive (spindle) pulley and thus, the blade, by three V-Belts. As the engine shaft rotates, so does the blade. The ratio, or difference between the engine speed and the spindle (blade) speed is determined by the two different sizes of pulleys used.

Refer to the **Engine Owner's Manual** for specific instructions regarding engine operation and maintenance practices.

All STOW CUTTER 1 CE saws are designed, engineered and manufactured with strict adherence to American National Standards Institute, Inc. (ANSI) guidelines B7.1 and B7.5.

Water System

All CUTTER 1 CE saws provide a hardy water plumbing system that evenly distributes water volume and optimum flow rate to both sides of the blade to keep it cool when cutting. The basic water system provides a valve that connects to a standard garden hose. The water is delivered (via a hose) to the saw blade. A water tank delivery system is optional.

Features

- Engine Stop Switch conveniently located on handle bar
- Super-rigid box frame- ensures straight cuts while resisting warping and blade vibration
- Rugged roller bearing wheels for long service life
- Comfortable grip handles
- Easy cranking for manually raising/lowering the blade to the desired cutting height
- Hinged front, lift-up blade guard is designed to provide easy blade replacement
- Saw position guide helps ensure straight cuts
- Water system provides optimum flow and volume of water to both sides of the blade
- manually operated wheel clamps help to prevent unwanted displacement of saw

STOW CUTTER 1 CE SAW — CONTROLS & COMPONENTS

CONTROLS & COMPONENTS

Figure 3 shows the location of the basic controls or components for the CUTTER 1 CE. Listed below is a brief explanation of each control or component.

1. **Hand Grips/Handlebar** – When operating the saw, place both hands on each grip to maneuver the saw. Replace hand grips when they become worn or damaged.
2. **Handle Lock** – Lock blade depth to desired position.
3. **Garden Hose Connector** – Connect to water source to provide blade cooling while cutting concrete or asphalt.
4. **Air Filter** – Prevents dirt and debris from entering the engine air intake. Check filter periodically and replace when necessary.
5. **Recoil Starter Handle** – Pull to engage and start the engine.
6. **Recoil Starter Assembly** – Engages the engine when the handle is pulled and rewinds the starter rope when the handle is released.
7. **Wheels/Carriage Assembly** – Heavy-duty wheels with permanently sealed ball bearings.
8. **Cutting Blade** – Use appropriate type blades for cutting concrete or asphalt.
9. **Blade Guard** – Covers saw blade and flips up to allow blade to be changed.
10. **Belt Tension Adjuster** – Adjusts belt tension.
11. **Front Pointer** – Front pointer wheel assists in straight tracking.
12. **Front Pointer Arm** – Stows up for storage and pivots down for use.
13. **Cutting Depth Adjuster** – turn operating crank clockwise or counter-clockwise to adjust the cutting depth up or down.
14. **Fuel Tank** – Use unleaded gasoline. Do not overfill.
15. **Blade Coolant System** – provides cooling water to blade during cutting operations.
16. **V-Belt Cover** – Remove this cover to gain access to the V-belts. **NEVER** operate the saw with this cover removed.
17. **Spindle Grease Zerks** – Conveniently located for lubrication.
18. **On/Off Switch (On Engine)** – Turn to the "ON" position to allow engine to be started and turn to the "OFF" position to shut the engine off.
19. **Tool Rotation** – Rotational direction of tool (blade) during operation.
20. **Engine Stop Switch (On Handlebar)** – Toggle in either direction to stop the engine.
21. **Wheel Clamp** – Move handle down making contact with wheel to avoid unwanted rolling movement. Lift handle to release.
22. **Water Valve** – Rotate handle to turn water supply on or off.

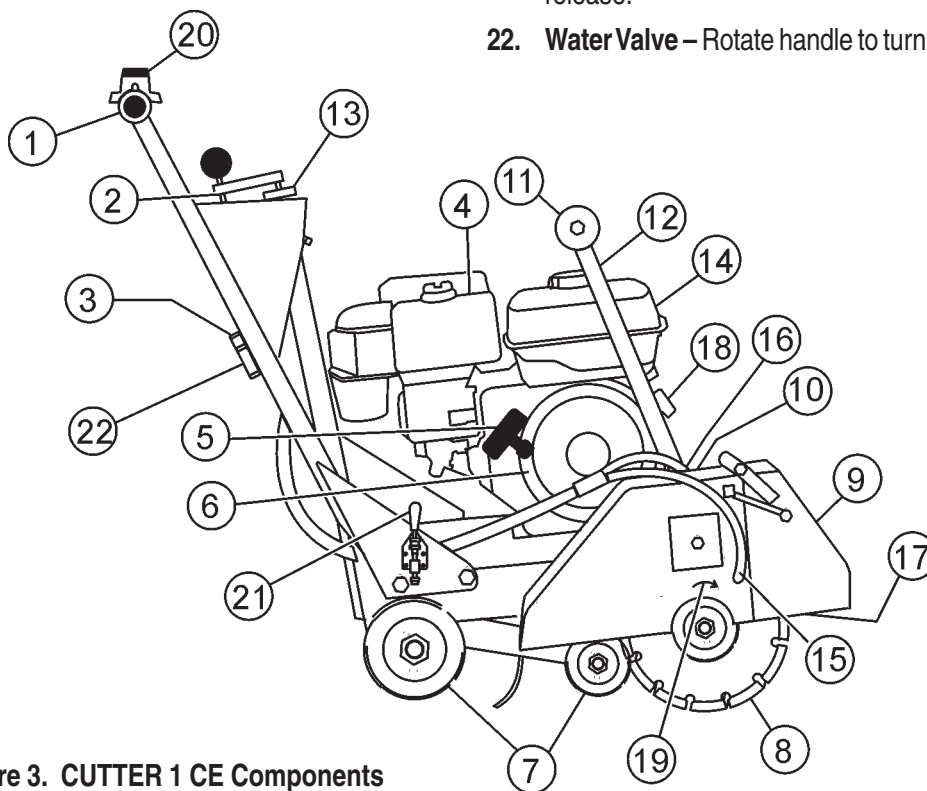

Figure 3. CUTTER 1 CE Components

STOW CUTTER 1 CE SAW — BASIC ENGINE

BASIC ENGINE

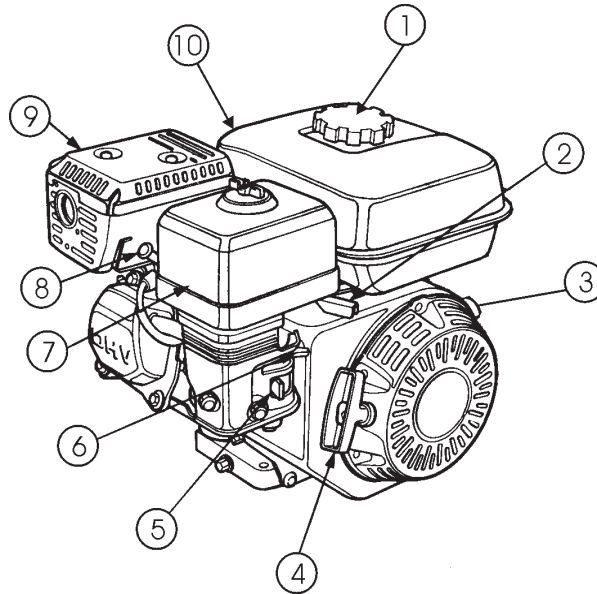

Figure 4. Engine Controls and Components

Initial Servicing

The engine (Figure 4) must be checked for proper lubrication and filled with fuel prior to operation. Refer to the manufacturer's engine manual for instructions & details of operation and servicing.

1. **Fuel Filler Cap** – Remove this cap to add unleaded gasoline to the fuel tank. Make sure cap is tightened securely. **DO NOT** over fill.

6. **Choke Lever** – Used in the starting of a cold engine, or in cold weather conditions. The choke enriches the fuel mixture.
7. **Air Cleaner** – Prevents dirt and other debris from entering the fuel system. Remove wing-nut on top of air filter cannister to gain access to filter element.

DANGER

Adding fuel to the tank should be done only when the engine is stopped and has had an opportunity to cool down. In the event of a fuel spill, **DO NOT** attempt to start the engine until the fuel residue has been completely wiped up, and the area surrounding the engine is dry.

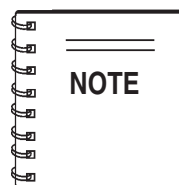

Operating the engine without an air filter, with a damaged air filter, or a filter in need of replacement will allow dirt to enter the engine, causing rapid engine wear.

2. **Throttle Lever** – Used to adjust engine RPM speed (lever advanced forward **SLOW**, lever back toward operator **FAST**).
3. **Engine ON/OFF Switch** – **ON** position permits engine starting, **OFF** position stops engine operations.
4. **Recoil Starter (pull rope)** – Manual-starting method. Pull the starter grip until resistance is felt, then pull briskly and smoothly.
5. **Fuel Valve Lever** – **OPEN** to let fuel flow, **CLOSE** to stop the flow of fuel.

8. **Spark Plug** – provides spark to the ignition system. Clean spark plug once a month.
9. **Muffler** – Used to reduce noise and emissions.

WARNING

Engine components can generate extreme heat. To prevent burns, **DO NOT** touch these areas while the engine is running or immediately after operating. **NEVER** operate the engine with the muffler removed.



10. **Fuel Tank** – Holds unleaded gasoline. For additional information refer to engine owner's manual.

STOW CUTTER 1 CE SAW — PREPARATION/PRE-INSPECTION

PREPARATION / PRE-INSPECTION

1. Read and fully understand this manual, the safety instructions in particular, and the engine manufacturer's manual supplied with the saw.

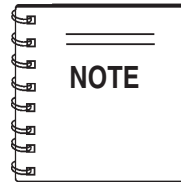

Reference manufacturer engine manual for specific servicing instructions.

2. Select the correct blade for each application. Refer to the Blades and Blade Placement sections on pages 19 through 21 for further information.

3. Check blade for wear or damage. Handle all blades with care and **ALWAYS** replace a damaged blade.



4. Clean the **saw**, removing dirt and dust, particularly the engine cooling air inlet, carburetor and air cleaner.
5. Check the air filter for dirt and dust. Replace the air filter if it is found to be dirty.
6. Check carburetor for external dirt and dust. Clean with dry compressed air.
7. Check fastening nuts and bolts for tightness.
8. Ensure a suitable water supply is available, hooked up, and used. (connected via garden hose or with an optional water tank supply system).

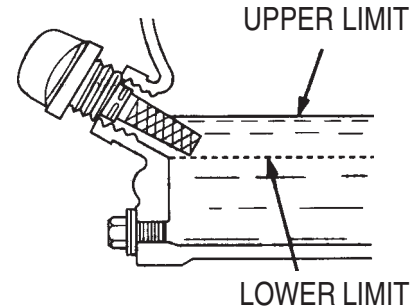

Figure 6. Engine Oil Dipstick (Oil Level)

Table 3. Oil Type

| Season | Temperature | Oil Type |
|-------------|----------------|---------------|
| Summer | 25°C or Higher | SAE 10W-30 |
| Spring/Fall | 25°C~10°C | SAE 10W-30/20 |
| Winter | 0°C or Lower | SAE 10W-10 |

Engine Oil Check

1. To check the engine oil level, place the saw on secure level ground with the engine stopped. The frame platform **must be level** to accurately check the engine oil.
2. Remove the filler dipstick from the engine oil filler hole (Figure 5) and wipe it clean.

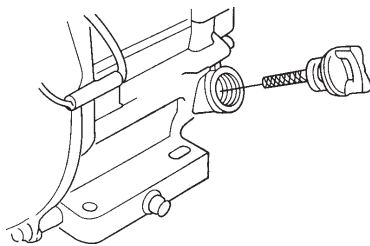

Figure 5. Engine Oil Dipstick (Removal)

3. Insert and remove the dipstick without screwing it into the filler neck. Check the oil level shown on the dipstick.
4. If the oil level is low (Figure 6), fill to the edge of the oil filler hole with the recommended oil type (Table 3).

Fuel Check

Warning

Motor fuels are highly flammable and can be dangerous if mishandled. **DO NOT** smoke while refueling. **DO NOT** attempt to refuel the saw if the engine is **hot!** or **running**.

1. Remove the gasoline cap located on top of fuel tank.
2. Visually inspect to see if fuel level is low. If fuel is low, replenish with unleaded fuel.
3. When refueling, be sure to use a strainer for filtration. **DO NOT** top-off fuel. Wipe up any spilled fuel.

STOW CUTTER 1 CE SAW — PREPARATION/PRE-INSPECTION

Guards And Covers

WARNING



NEVER operate the saw without blade guards and covers in place. **DO NOT** operate with the front of the blade guard raised. The blade exposure cannot exceed 180 degrees during operation. Adhere to the safety guidelines or other applicable local regulations.

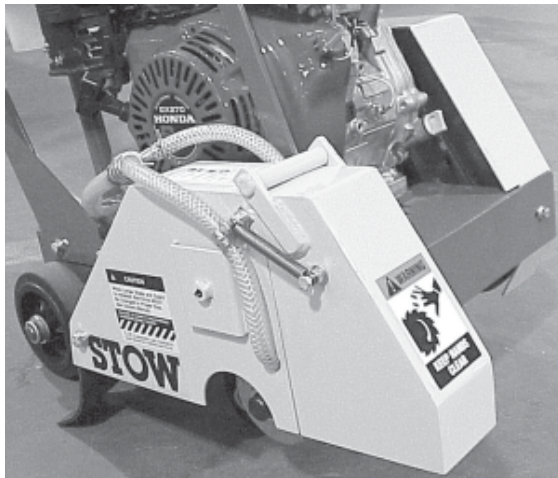

Figure 7. Blade Guard

CHECK the following on the **blade guard** (Figure 7):

- Ensure the capacity of the blade guard is correct for an 18" Diamond Blade.
- Check that the guard is bolted firmly upon the saw frame.
- Check that the spring tensioned front cover of the guard is firmly seated with the rear section of the guard and there are no gaps. **NEVER** lift the blade guard while engine is running.

ENSURE the **V-belt Cover** is in place and securely fastened during operation of the saw (Figure 7).

V-Belt Check

A worn or damaged V-belt can adversely affect the performance of the saw. If a V-belt is defective or worn, replace **ALL** the V-belts. V-belts should always be replaced in sets.

WARNING

NEVER attempt to check the V-belt with the engine running. Severe injury can occur. Keep fingers, hands, hair, and clothing away from all moving parts.

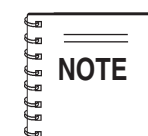

V-belt alignment must be rechecked after adjusting belt tension.

V-belt Alignment and Tensioning

This saw is equipped with premium V-belts that have been aligned and tensioned by factory personnel. The V-belt must be aligned and tensioned for proper operation of the saw.

Use the following procedure to check the alignment of V-belt:

1. Remove the bolts that secure the V-belt cover (Figure 8) to the saw frame.

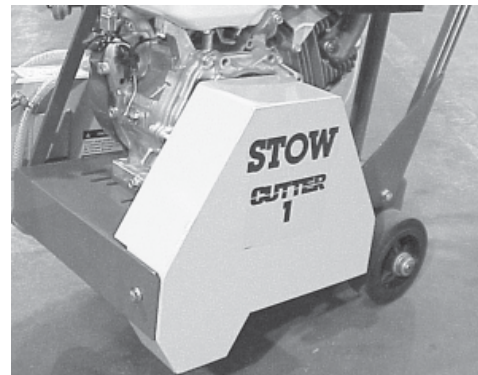

Figure 8. V-Belt Cover

2. Check uniform parallelism (Figure 9) of V-belt and pulley (sheaves). Use a straight-edge or machinist's square against both pulleys and adjust both pulleys until equally aligned.

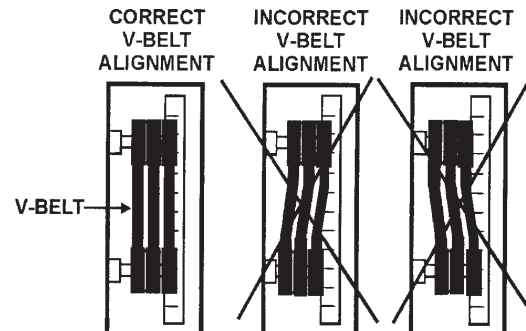

Figure 9. Pulley Alignment

3. Check V-belt tension by using a tension meter (3.0 lbs./ 1.36Kg) against the inside belt at a mid point between the two pulleys, or by deflecting the center belt at a mid point 3/16" (5 mm).
4. **DO NOT** over or under tighten the V-belt. Severe damage can occur to the saw and engine crankshaft if the belt is over-tensioned. A decrease of power to the blade and poor performance will result if the belt is under-tensioned (loose on pulleys).

STOW CUTTER 1 CE SAW— BLADES

SPECIFIC TOOLS TO BE USED

This saw is to use tools (blades) as follows:

Steel Core Segmented or Continuous Diamond Rim Cutting Wheel.

Any other type of tool is not to be used. See Table 4 for specific blade usage for material.

WARNING

Failure to thoroughly inspect the diamond blade (Figure 10) for operational safety could result in damage to the blade or the saw, and may cause injury to the user or others in the operating area. Discard damaged or worn blades and replace with fresh blade.

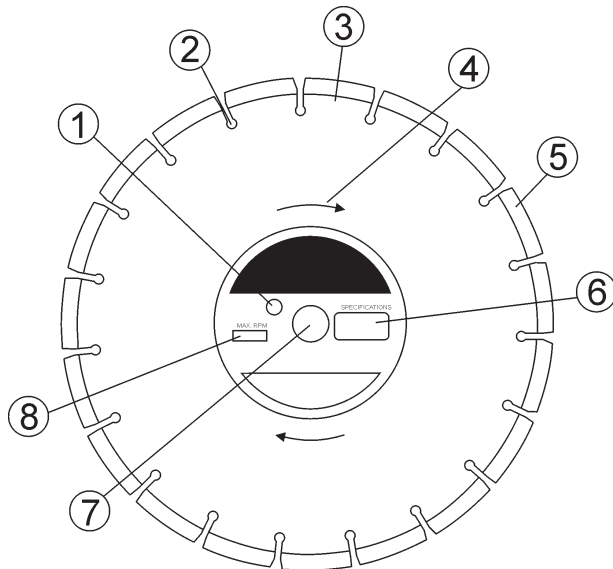

Figure 10. Diamond Blade

1. **Drive Pin Hole** – A commonly located hole on the diamond blade core that prevents operational blade slippage between the inner & outer blade flanges (collars). Inspect the diameter of the hole to ensure there is no distortion, and that a snug fit develops between the hole and drive pin.
2. **Stress Relief Holes (Gullets)** – Check the steel core for cracks that may have propagated from the slots and/or gullets. Cracks indicate extreme fatigue failure and if sawing continues, catastrophic failure will occur.
3. **Edge Of The Steel Core** – Check the diameter edge for discoloration (blue oxidation) indicating an overheating condition caused by insufficient cooling water/air. Overheating of blades may lead to loss of core tension and/or increase the possibility for blade failure. Check to make sure the steel core's width is uniform about the rim of the blade, and not succumbing to an “under cutting” condition brought about by highly abrasive material or improper under cutting core protection.
4. **Directional Arrow** – Check to ensure that the blade is oriented properly on the spindle for sawing. Reference the directional arrow on the blade and place it so the direction of rotation “downcuts” with the turn of the shaft.
5. **Diamond Segment or Rim** – Ensure there are no cracks, dings, or missing portions of the diamond segment/rim. **DO NOT use a blade that is missing a segment or a portion of the rim.** Damaged and/or missing segments/rims may cause damage to your saw, and injury to the user or others in the operating area.
6. **Specifications** – Ensure that the blade specifications, size, and diameter properly match up to the sawing operation. Wet blades must have water to act as a coolant. Utilizing a diamond blade not matched properly to the task may result in poor performance and/or blade damage.
7. **Arbor Hole** – It is essential that the arbor hole diameter properly matches the shaft arbor, and that it is free from distortions. Correct blade flanges (collars) must be used. The inside face of the flanges must be clean & free of debris. An out of round arbor condition will cause damage to the blade and the saw.
8. **MAX RPM** – This RPM reference is the maximum safe operating speed for the blade selected. **NEVER** exceed the max RPM on the diamond blade. Exceeding the MAX RPM is dangerous, and may cause poor performance and may damage the blade. All blades used must be designed for the maximum spindle RPM.

STOW CUTTER 1 CE SAW— BLADE PLACEMENT

Table 4. MATERIAL LISTING AND BLADE SELECTION

| Material | Blade |
|-------------------------------------|------------------------|
| Cured Concrete | Cured Concrete Blade |
| Green Concrete | Green Concrete Blade |
| Asphalt | Asphalt Blade |
| Asphalt over Concrete | Asphalt/Concrete Blade |
| Block, Brick, Masonry, Refractories | Masonry Blade |
| Tile, Ceramic, Stone | Tile Blade |

Diamond Blades

Selecting the diamond blade **TYPE** and **GRADE** defines how the blade will perform both in cutting speed and blade life.

Selection of the proper diamond blade consists of:

- Material to be Cut
- Type of Saw Being Used
- Horsepower of Saw
- Hardness Characteristics of the Material
- Performance Expectations

Factors for sawing economy:

- Type of Blade
- Depth of Cut
- Sawing Speed
- Characteristics of the Material Being Cut

Blade Speed

A diamond blade's performance is directly connected to specific peripheral (rim) speeds.

The following shaft rotational speeds have been factory set to ensure optimum blade performance.

- CUTTER 1 CE 18" Capacity - 2,836 RPM.

WARNING

Operating saw blades at rotational speeds greater than those specified by the manufacture can cause blade damage, and may injure the user or others in the operating area.



BLADE PLACEMENT

Refer to Figure 11.

WARNING



Failure to thoroughly inspect the diamond blade for operational safety could result in damage to the blades or the saw and may cause injury to the user or others in the operating area.

1. **Engine OFF** - Set the ENGINE ON/OFF switches to the "OFF" position to prevent accidental starting.
2. **Blade Guard** - Pivot the blade guard front cover all the way back. The guard tension spring will keep the front cover in position.
3. **Blade Hex Nut** - Unscrew the spindle nut (right side loosens clockwise and tightens counter-clockwise while the left side loosens counter-clockwise and tightens clockwise. **DO NOT** overtighten the nut (approximately 45-50 ft. lb/61-68 N/m) when finalizing the assembly.
4. **Outside Blade Flange (Collar)** - Ensure that the outside blade flange is placed flush against the diamond blade. The inside surface of the flange must be free of debris and permit a tight closure on the surface of the blade core.
5. **Diamond Blade** - Ensure that the proper diamond blade has been selected for the job. Pay close attention to the directional arrows on the blade. The blade's operating directional arrows must point in a "down-cutting" direction to perform correctly. When placing the blade onto the spindle, ensure the arbor hole of the blade matches the diameter of the shaft.

STOW CUTTER 1 CE SAW— BLADE PLACEMENT

6. **Inner Flange (Collar)** - This flange is fixed upon the spindle. The inside surface of the flange must be free of debris and permit a tight closure on the surface of the blade.

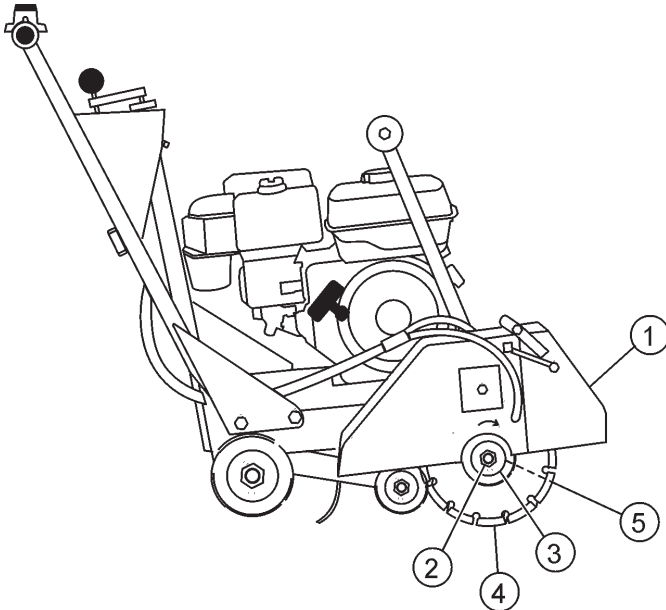
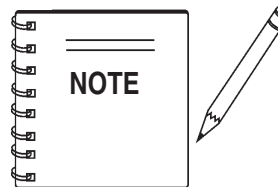

Figure 11. Tool (Blade) Placement

Blade Removal and Replacement

1. Set the ENGINE ON/OFF switches to the "OFF" position to prevent accidental starting.
2. Place the saw on a stable level working surface.
3. Ensure the blade is raised and the raise/lower crank is locked into position.



When removing or installing a diamond blade, please note that the blade retaining nuts are left and right-hand threaded.

4. Lift up the blade guard cover to gain access to the blade.

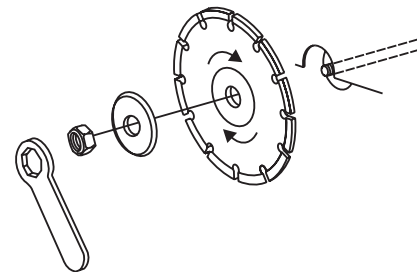

Figure 12. Tool (Blade) Wrench

WARNING

Incorrectly installed blades can cause damage to the blade or equipment or cause injury due to breakage.

WARNING

Dropping or forcing the blade onto the cutting surface can severely damage the diamond blade and may cause serious damage to the saw and bodily harm.

5. Use the provided blade nut wrench to remove and install the blade. (Figure 12)
6. Unscrew the spindle nut (right side loosens clockwise and tightens counter-clockwise while the left side loosens counter-clockwise and tightens clockwise). **DO NOT** overtighten the nut (approximately 45-50 ft. lb/61-68 N/m) when finalizing the assembly.

STOW CUTTER 1 CE SAW— RAISE/LOWER AND DEPTH STOP

Raise/Lower and Depth Stop

The saw is equipped with a Raise/Lower and Depth Stop Assembly that is supported by the following components. (Figure 13)

1. Adjusting Hand Crank Assembly
2. Raise/Lower Acme Screw
3. Jack Arm
4. Wheel Base Assembly
5. Jackshaft Pin
6. Lock Positions

Setting the Depth Stop

1. Lift the Adjusting Hand Crank to unlock (disengage) the Depth Stop.
2. Rotate the crank to raise or lower the blade to the desired depth.
3. Lower the crank into one of the lock position holes (Item 6).

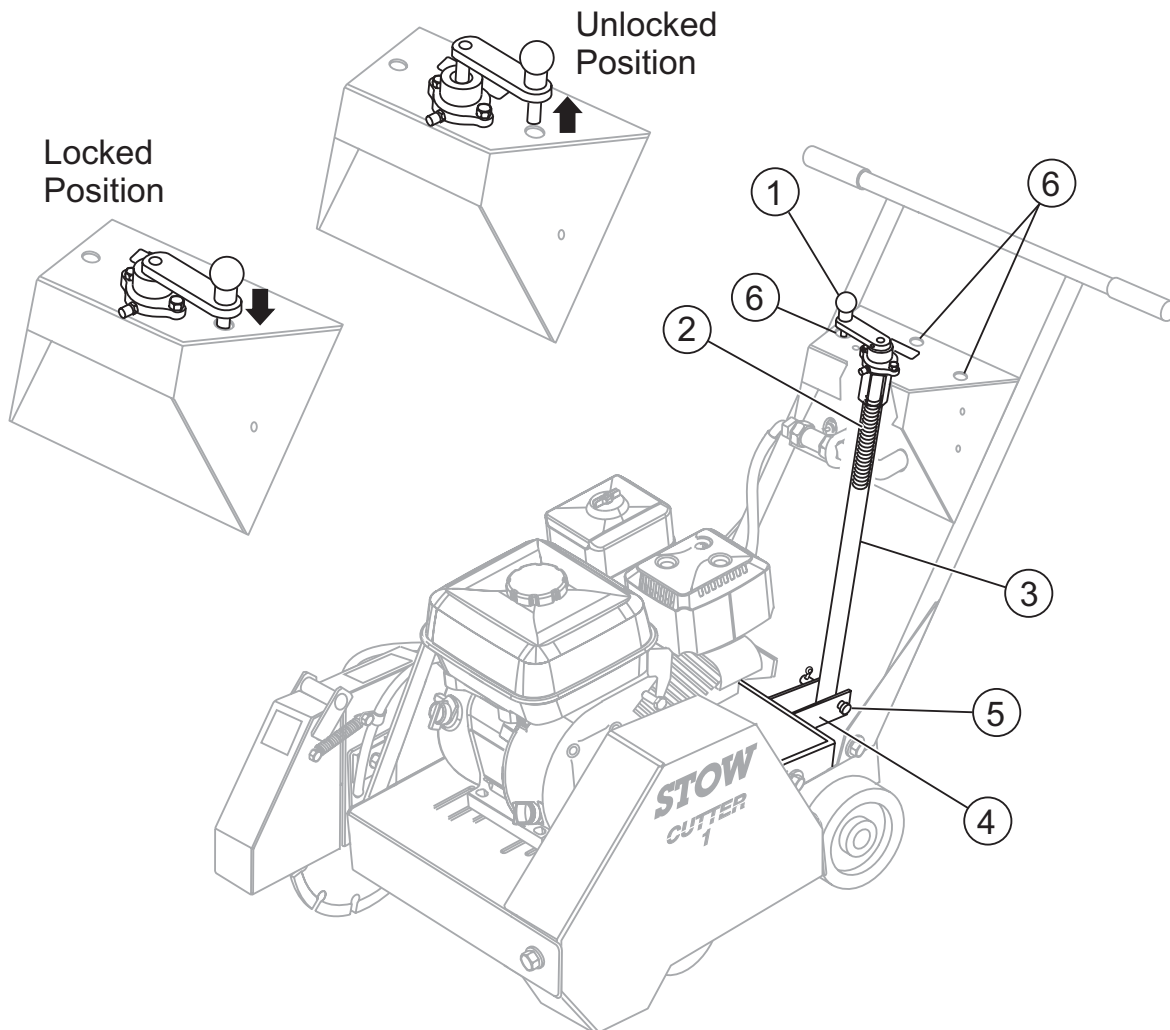

Figure 13. Cutting Depth - Raise/Lower System

STOW CUTTER 1 CE SAW — INITIAL START-UP

INITIAL START-UP

CAUTION

DO NOT attempt to operate the saw until this manual has been read and thoroughly understood. Engine operating steps may vary. See included engine manufacturer's operating manual.



CAUTION

Ensure the work area is clear of tool, debris, and unauthorized people.

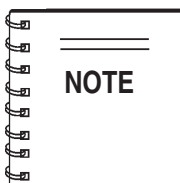

The Engine Stop Switch located on the handlebar (Figure 14) serves both as an Emergency Engine Shut-Off and as the primary ON/OFF switch. This allows the operator to shutdown the saw safely away from moving parts.

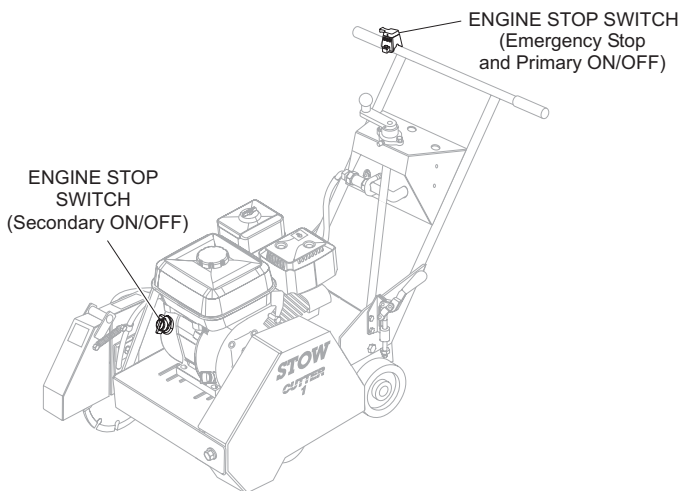

Figure 14. Engine Stop Switches

WARNING

NEVER operate the saw in a confined area or enclosed structure that does not provide ample **free flow of air**.



ALWAYS wear approved eye and hearing protection while operating the saw.



CAUTION

NEVER place hands or feet inside the belt guard or blade guard while the engine is running. **ALWAYS** shut the engine down before performing any kind of maintenance service on the saw



1. Keep Wheel Clamp (Figure 15) applied (lever **DOWN**) until completely ready for cutting operation.

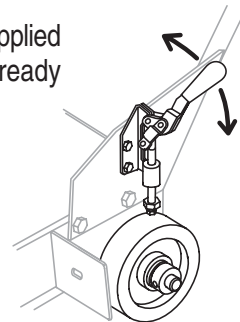

Figure 15. Wheel Clamp

2. Ensure the diamond blade has been mounted correctly and that it is raised above the surface you are about to saw.
3. Place the **fuel valve lever** (Figure 16) to the "ON" position.

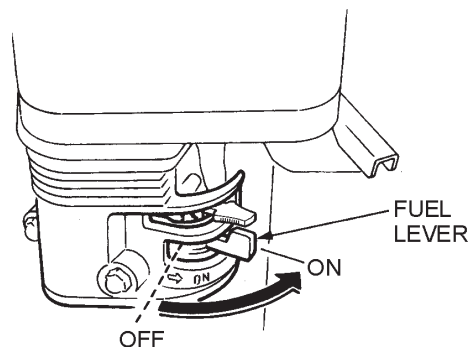

Figure 16. Engine Fuel Valve Lever

4. Place the **ENGINE ON/OFF switch** located on the **ENGINE** (Figure 18) in the "ON" position. Place the **ENGINE ON/OFF switch** located on the **HANDLEBARS** (Figure 14) in the "ON" (center) position.

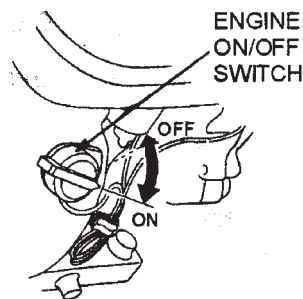

Figure 17. Engine ON/OFF Switch (On Engine)

STOW CUTTER 1 CE SAW — INITIAL START-UP

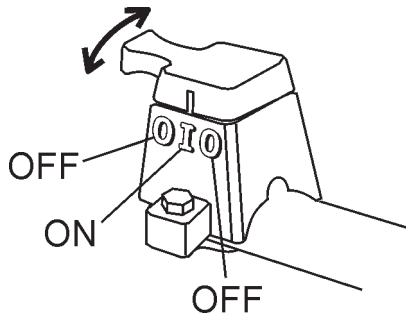

Figure 18. Engine Stop Switch (Handlebar)

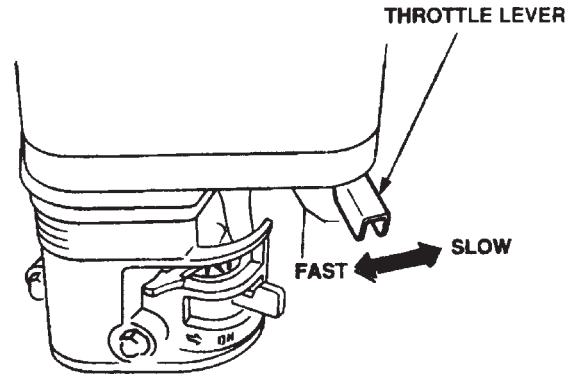
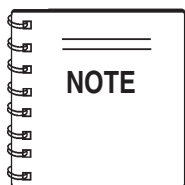

Figure 20. Throttle Lever



The **CLOSED** position of the choke lever enriches the fuel mixture for starting a **COLD** engine. The **OPEN** position provides the correct fuel mixture for normal operation after starting, and for restarting a warm engine.

- Place the **Choke Lever** (Figure 19) in the "**CLOSED**" position.

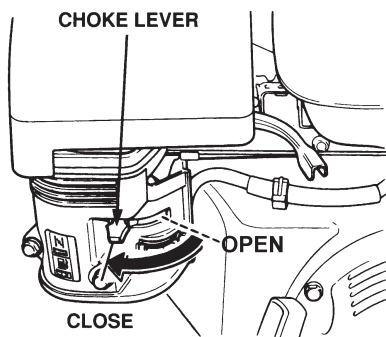

Figure 19. Choke Lever

CAUTION

DO NOT pull the starter rope all the way to the end. **DO NOT** release the starter rope after pulling. Allow it to rewind as soon as possible.

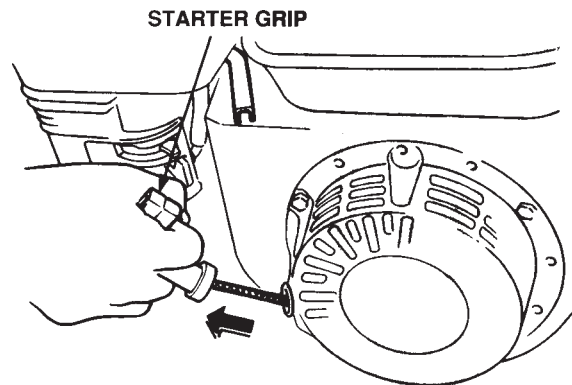



Figure 21. Starter Grip

CAUTION

The engine speed has been set at the factory. Changing the governor speed could damage the blade and/or the saw.



- Rotate the **throttle lever** (Figure 20) halfway between **fast** and **slow** for starting. All sawing is done at **full throttle**. The engine governor speed is factory set to ensure optimum blade operating speeds.
- If the engine has started, slowly return the choke lever (Figure 20) to the "**OPEN**" position. If the engine has not started repeat steps 1 through 7.
- Before the saw is placed into operation, run the engine for several minutes. Check for fuel leaks, and noises that could be associated with loose guards and/or covers.

STOW CUTTER 1 CE SAW — OPERATION

OPERATION

WARNING

ALWAYS cut with the saw at **FULL THROTTLE**. Attempting to cut with the saw at less than full throttle could cause the blade to bind or stop abruptly in the slab resulting in serious injury to the operator or others in the area.

WARNING

ALWAYS keep clear of **rotating** or **moving** parts while operating this equipment.

CAUTION

Ensure the cutting area is clear of tools, debris, and unauthorized people.

CAUTION

DO NOT try to cut faster than the blade will allow. Cutting too fast will cause the blade to rise up out of the cut. Improper cutting rate can decrease the life of the engine and blades.

CAUTION

Engine components and the blade can get **EXTREMELY HOT!** during operation. **ALWAYS** allow the engine and blade to cool before handling or servicing.



CAUTION

Whenever the saw is not in operation or being moved or transported, apply the wheel clamp brakes to prevent unwanted displacement.

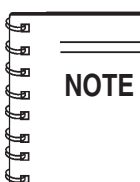

Mark the cutting line clearly and always saw in a **STRAIGHT LINE ONLY**.

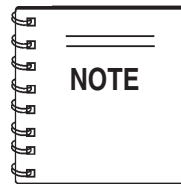

The Engine Stop Switch located on the handlebar (Figure 18) serves both as an Emergency Engine Shut-Off and as the primary ON/OFF switch. This allows the operator to shutdown the saw safely away from moving parts.

1. Start the engine as described in the previous section. Rotate the throttle lever (Figure 20) toward full throttle. Ensure water supply system is in operation. Turn valve to start flow of water. (For water tank option, see page 29.)
2. Release Wheel Clamps by pulling levers **UP**.

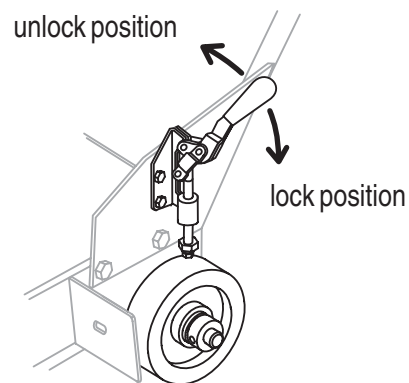

Figure 22. Wheel Clamp

3. To begin sawing, use the raise/lower crank handle on the console to lower the rotating blade allowing it to cut to the preset depth.
4. When blade has reached full cutting depth, slowly walk behind the saw at a rate that will allow the engine to operate without losing optimum RPM.
5. When the end of the cut has been reached, use the raise/lower crank on the console to raise the blade out of the cut.
6. When cutting is complete, turn the engine **OFF** using the **ENGINE STOP TOGGLE SWITCH** on the handlebars, and wait for the blade to stop rotating.
7. Set the engine **ON/OFF** switch to the **OFF** position.
8. Place the water valve in the **OFF** position (as required).
9. Push the Wheel Clamp Levers downward to apply braking pressure to the wheels (Figure 22).

STOW CUTTER 1 CE SAW — OPERATION

Restarting After Intervention

If cutting is interrupted where the engine stops or is turned off while the blade is still in the cut:

- a. Turn Engine Off switches to "**OFF**".
- b. Raise the blade out of the cut
- c. Restart the engine as described in the previous section.
- c. Lift the guard up and back until the retaining spring acts to hold the guard in the "up" position.
- d. Return to the operator position between the handles.
- e. Restart the blade rotation.
- f. Carefully cut up to the vertical surface and then back up enough to allow the blade guard to be lowered.
- g. Stop the blade rotation.
- h. Lower the blade guard to its original position.

CAUTION

The only acceptable method for freeing a stuck blade is to remove the saw from the stuck or pinched blade. **DO NOT** try to get the blade unstuck using the Raise/Lower system or by lifting the saw by the lifting bale, etc.

If cutting is interrupted where the blade is stuck in the cut:

- a. Turn Engine Off switches to "**OFF**".
- b. Remove the blade guard.
- c. Remove blade mounting bolt and outer flange.
- d. Maneuver the saw away from the stuck blade.
- e. A parallel cut made next to the blade may be necessary to free it.
- f. Once the blade is freed inspect the blade for damage; discard if damaged.
- e. Ensure an undamaged, useable blade is installed on the saw before cutting is resumed with that saw.

Cutting Close to a Vertical Surface

Follow the following procedures when cutting up to a vertical surface (wall, steps, etc.).

WARNING!

Use **EXTREME CAUTION** when performing the the following operations:



- a. Stop blade rotation far enough from vertical surface to permit lifting front section of blade guard.
- b. Grasp the front section of the blade guard from the outside only (**NEVER** extend fingers into guard!)

STOW CUTTER 1 CE SAW — MAINTENANCE

MAINTENANCE

See the engine manual supplied with your machine for appropriate engine maintenance schedule and troubleshooting guide for problems.



General maintenance practices are crucial to the performance and longevity of your saw. The extreme environments of sawing operations require routine cleaning, lubrication, belt tensioning, and inspection for wear and damage.

The following procedures devoted to maintenance performed by competent persons can prevent serious saw damage or malfunctioning.

- **REMOVING** or **INSTALLING** blades
- **ADJUSTING** front or rear pointers
- **LUBRICATING** any components
- **REMOVING** engine mounting bolts
- **INSPECTING, ADJUSTING, OR REPLACING** drivebelt, spindle, spindle bearings or **ANY** engine part
- **REMOVING** blade or belt guards



DANGER

Some maintenance operations may require the engine to be run. Ensure that the maintenance area is well ventilated. Exhaust contains poisonous carbon monoxide gas that can cause of unconsciousness and may result in **DEATH**.



WARNING

Before servicing or inspection, **ALWAYS** park the saw on a level surface with the blade removed, and the handlebar Engine **ON/OFF** switch & Engine **ON/OFF** switch in "OFF" position.



CAUTION

ALWAYS ensure that both **ENGINE ON/OFF** switches (on the handlebar and on the engine) are in the "OFF" position, and that the spindle has **COMPLETELY STOPPED ROTATING** before performing any of the the following operations:



CAUTION

ALWAYS allow the engine to cool before servicing. **NEVER** attempt any maintenance work on a **hot!** engine.



Saw Blade Removal and Installation

See page 21.

General Cleanliness

Clean the machine daily. Remove all dust and slurry build up. If the saw is steam cleaned, ensure that lubrication is accomplished **AFTER** steam cleaning operations.

Chassis Lubrication

- **Spindle Bearings** - Two zerk fittings are located up under the lower-front of the saw. Lubricate before daily use. Use a good quality extreme pressure grease. Check and lubricate more often if unit is under heavy use. Do not overfill bearings. Overfilling can damage the grease seals. This can result in bearing exposure to dirt and contaminants which can then shorten the life of the bearings. Excess grease can also drip onto the cutting surface.

Drive Belt

Refer to page 18 of this manual for Drive Belt adjustment procedures and Removal and Replacement procedures.

General Engine Care

Engine check:

Check daily for any oil and/or fuel leakage, thread nut & bolt tightness, and overall cleanliness.

Engine air filter:

Replace air filter if dirty. See Engine Owner's Manual for detailed information.

Engine oil:

Check daily. Inspect with blade removed and saw frame level on a level surface. Keep the oil clean, and at the proper servicing level (Figure 7). **DO NOT OVERFILL!** SAE 10W-30 of SG is recommended for general use.

STOW CUTTER 1 CE SAW — MAINTENANCE

Engine oil change:

Change engine oil the first month or 20 hours of operation. Then every 3 months/or 50 HOURS of operation. See Engine Owner's Manual for detailed information.

Drain the used oil while the engine is warm by the following method:

Refer to Figure 23.

1. Place an oil pan or suitable container below the engine drain plug to catch the used oil.
2. Remove the filler cap/dipstick and the drain plug.
3. Drain the oil completely and reinstall the drain plug. Ensure the drain plug is tightened securely.
4. Make sure the engine is in a level position and fill to the outer edge of the oil filler hole with the recommended oil. (See Table 3.) Engine oil capacity is 1.16 US quart (1.1 liter).
5. Screw in the filler cap/dipstick securely.

CAUTION
Running the engine with a low oil level can cause engine damage.

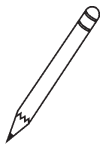
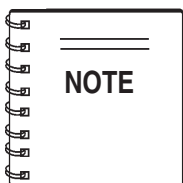

Dispose of used oil properly. **DO NOT** pour used oil on the ground, down a drain, or throw in the trash. Used oil can generally be taken to your local recycling center or service station for reclamation. Follow all required

environmental rules and regulations required in your area concerning the disposal of hazardous waste such as used oil and oil filters.

Engine tank & strainer:

Clean every year/or 300 hours.

Fuel line:

Replace every two years/or as necessary.

Spark plug:

Clean/adjust every 6 months/or 100 hours. Replace every year/ or 300 hours.

Front Pointer Adjustment

The front pointer wheel has been set at the factory. Use these procedures only if the pointer is suspect of being out of alignment.

1. Chalk out a straight line on the prepared slab or cutting surface.
2. Use a straight-edge or level by placing it flat against the blade.
3. Adjust the front pointer wheel so it just touches the side of the straight-edge or level.
4. Remove the straight-edge or level.
5. Position the front pointer and blade directly over the chalk line.
6. Start the saw and lower the blade onto the chalk line.
7. Begin cutting and make sure the blade follows the chalk line as closely as possible.
8. The pointer should follow the chalk line as well. If it does not, adjust the pointer by loosening then tightening the jam nuts on the pointer until the pointer follows the same path as the blade.

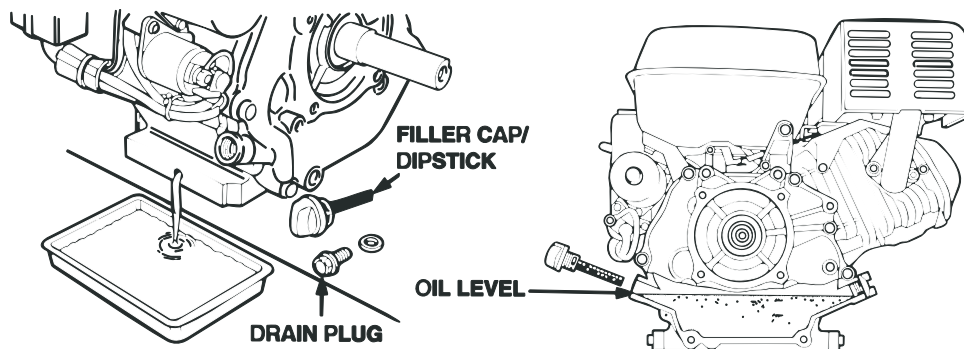

Figure 23. Engine Oil Change

STOW CUTTER 1 CE SAW — OPTIONAL WATER TANK

WATER TANK KIT (OPTION)

An optional water tank kit is available for use with the CUTTER 1 CE Saw. The following steps are instructions for the assembly of the kit onto your CUTTER 1 CE Saw.

CAUTION

Make certain all bolts securing the kit to the saw are tight before operating the saw.

CAUTION

DO NOT use a water tank larger than 5 gallons (18.95 liters) with this kit.

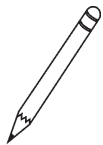
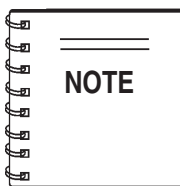

While the optional water tank kit is excellent for short-run cutting operations, the use of a pressurized, continual water source may be preferred for longer or sustained cutting.

1. Locate all parts listed in the parts list.
2. Slide the Tank Shelf (item 1, Figure 24) over the top of the engine so the recoil starter fits through the large opening in the shelf. The recoil starter handle must be accessible through this opening. Ensure the recoil starter handle can be pulled without binding or interference with the shelving.
3. Mount the Tank Shelf to the frame using hardware items 7, 9, 11, and 13 to attach the shelf to the frame utilizing existing slots in the frame.
4. Locate the spacers for the tank mount. This kit provides spacers for two different engine options. The spacers are identified as:

Honda 9HP - use 2-3/8" spacer

Honda 13HP - use 1-1/2" spacer

5. After determining the correct spacer length, place the spacers (item 12, Figure 24) between the engine block and the tank shelf bracket and secure the assembly with the 3/8" hardware (items 6, 8, and 10). Use the appropriate length bolt (item 6) for your application.

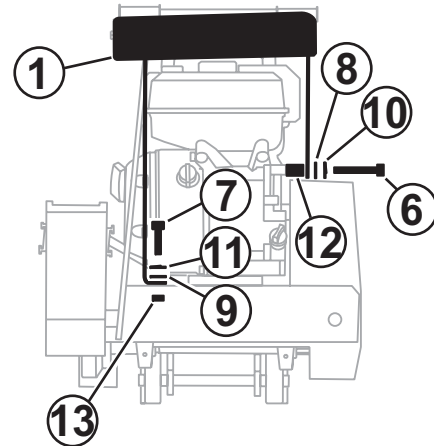

Figure 24. Water Tank Kit (Option)

6. Connect the Swivel Connector (item 5, Figure 25) to one end of the hose (item 3) with clamp (item 2).
7. Remove the hard plastic tube from the valve on the Water Tank (item 14). Slide this tube into the open end of the hose (item 3) to a depth of approximately 1 inch (25.4mm). Fasten with clamp (item 2).

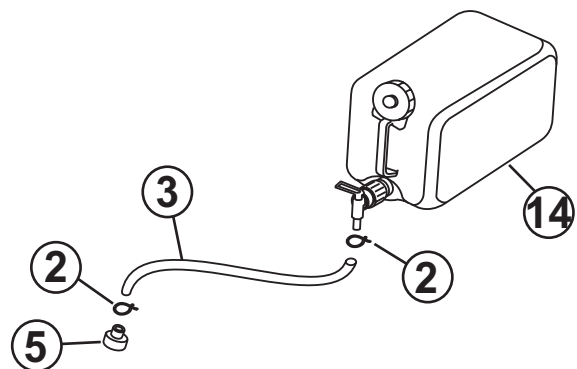

Figure 25. Hose and Clamps

8. Replace the hard plastic tube back into the Water Tank valve.

STOW CUTTER 1 CE SAW — OPTIONAL WATER TANK

- Place the Water Tank (with the hose assembled), onto the Tank Shelf so the valve and hose are resting in the notch of the top of the Tank Shelf. (Figure 26)
- Place the Bungee Cord (item 4) over the Water Tank (item 14) so it securely holds the tank onto the Shelf.
- Disconnect the existing water hose from the saw blade guard and connect instead, the new hose using the Swivel Connector. (item 5)

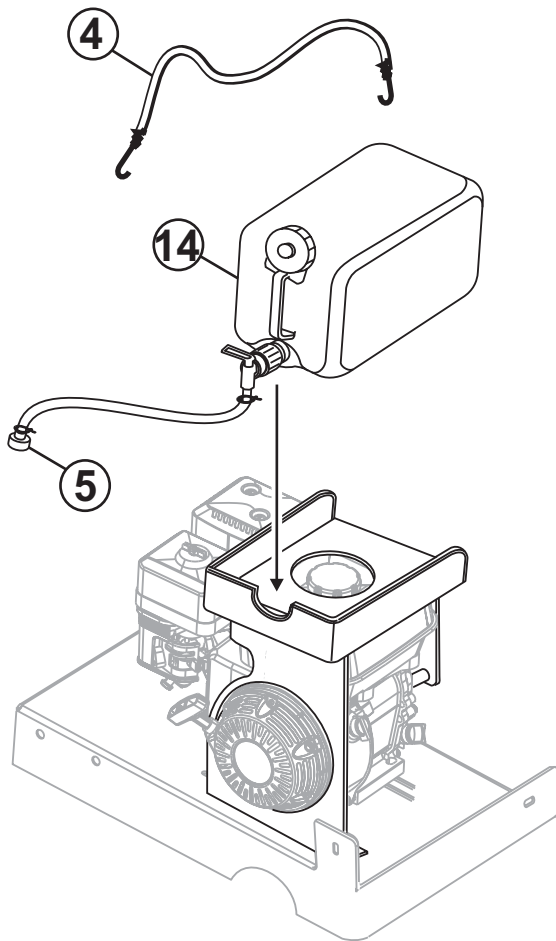

Figure 26. Water Tank Position

CAUTION

Remove the pre-existing water hose entirely or fasten it away from any contact or interference with the blade or any moving part.

Decommissioning Saw/Components

Decommissioning is a controlled process used to safely retire a piece of equipment that is no longer serviceable. If the equipment poses an unacceptable and unreparable safety risk due to wear or damage or is no longer cost effective to maintain, (beyond life-cycle reliability) and is to be decommissioned, (demolition and dismantlement), the following procedure must take place:

- Drain all fluids completely. These may include oil, gasoline, hydraulic oil and antifreeze. Dispose of properly in accordance with local and governmental regulations. Never pour on ground or dump down drains or sewers.
- The remainder can be brought to a salvage yard or metal reclamation facility for further dismantling.

STOW CUTTER 1 CE SAW — TROUBLESHOOTING (SAW)

TABLE 5. BLADE TROUBLESHOOTING

| SYMPTOM | POSSIBLE PROBLEM | SOLUTION |
|--|--|---|
| Blade slows or stops cutting. | Blade too hard for the material being cut? | Consult Dealer or Multiquip for correct blade. Try cutting very soft material (sandstone, silica brick, cinder block) to "Redress" the blade. |
| | Engine torque diminished because of loose V-belt? | Tighten and/or replace V-Belts. |
| | Insufficient engine power? | Check throttle setting. Check Engine horsepower. |
| | Improper direction of rotation? | Check that the blade is properly oriented and rotational arrow points in a "Down-Cutting" direction. |
| | Blade is slipping on the blade shaft? | Check that the blade & flange pin are properly installed on the blade shaft. |
| Blade does not cut straight and/or true. | Blade being used on misaligned saw? | Check blade shaft bearings and alignment integrity. |
| | Blade is excessively hard for the material being cut? | Check specification of the blade with the material being cut. Consult Dealer or Multiquip for information. |
| | Blade being used at improper RPM? | Ensure blade surface feet per minute speed (SFPM) is approximately 6,000. |
| | Blade improperly mounted on arbor shoulders and flanges? | Ensure blade is properly affixed on the blade shaft. |
| | Excessive force applied to blade while cutting? | DO NOT force the blade in the cut. Apply a slow and steady pace when sawing. |
| Blade discoloring, crackling and/or wearing excessively. | Blades too hard for the material being cut? | Consult Dealer or Multiquip for correct blade. Try cutting very soft material (sandstone, silica brick, cinder block) to "Redress" the blade. |
| | Blade improperly mounted on arbor shoulders and flanges? | Ensure blade is properly affixed on the blade shaft. |
| | Blade not receiving enough cooling water? | Ensure proper flow & volume of water is provided for wet cutting blades. |
| | Arbor hole out of round? | Ensure blade is properly affixed on the blade shaft. |
| | Incorrect blade chosen for material being cut? | Check specification of the blade with the material being cut. Consult Dealer or Multiquip for information. |
| | Excessive force applied to blade while cutting? | DO NOT force the blade in the cut. Apply a slow and steady pace when sawing. |

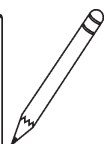
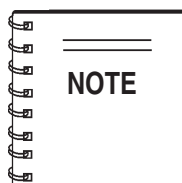

Certain operations referred to in this troubleshooting section such as re-seating valves or replacing piston rings may require special tools and must be performed by trained and competent personnel.

STOW CUTTER 1 CE SAW — TROUBLESHOOTING (ENGINE)

TABLE 6. TROUBLESHOOTING (ENGINE)

| SYMPTOM | POSSIBLE CAUSE | SOLUTION |
|--|---|---|
| Difficult to start, "fuel is available, but no SPARK at spark plug". | Spark plug bridging? | Check gap, insulation or replace spark plug. |
| | Carbon deposit on spark plug? | Clean or replace spark plug. |
| | Short circuit due to deficient spark plug insulation? | Check spark plug insulation, replace if worn. |
| | Improper spark plug gap? | Set to proper gap. |
| | Ignition coil defective? | Replace ignition coil. |
| Difficult to start, "fuel is available, and SPARK is present at the spark plug". | ON/OFF switch is shorted? | Check switch wiring, replace switch. |
| | Improper spark gap, points dirty? | Set correct spark gap and clean points. |
| | Condenser insulation worn or short circuiting? | Replace condenser. |
| | Spark plug wire broken or short circuiting? | Replace defective spark plug wiring. |
| Difficult to start, "fuel is available, spark is present and compression is normal". | Wrong fuel type? | Flush fuel system, and replace with correct type of fuel. |
| | Water or dust in fuel system? | Flush fuel system. |
| | Air cleaner dirty? | Replace air cleaner. |
| | Choke Open? | Close Choke. |
| Difficult to start, "fuel is available, spark is present and compression is low". | Suction/exhaust valve stuck or protruded? | Re-seat valves. |
| | Piston ring and/or cylinder worn? | Replace piston rings and/or piston. |
| | Cylinder head and/or spark plug not tightened properly? | Torque cylinder head bolts and spark plug. |
| | Head gasket and/or spark plug gasket damaged? | Replace head and/or spark plug gaskets. |
| No fuel present at the carburetor. | Fuel not available in fuel tank (tank empty)? | Fill with correct type of fuel. |
| | Fuel filter clogged? | Replace fuel filter. |
| | Fuel tank cap breather hole clogged? | Clean or replace fuel tank cap. |
| | Air in fuel line? | Bleed fuel line. |

STOW CUTTER 1 CE SAW — TROUBLESHOOTING (ENGINE)

TABLE 6. TROUBLESHOOTING (ENGINE, CONTINUED)

| SYMPTOM | POSSIBLE CAUSE | SOLUTION |
|---|--|---|
| "Weak in power" compression is proper and does not misfire. | Air cleaner not clean? | Replace air cleaner. |
| | Improper fuel level in carburetor? | Check float adjustment. |
| | | Rebuild carburetor. |
| | Defective spark plug? | Clean or replace spark plug. |
| Improper spark plug gap? | Set to proper gap. | |
| "Weak in power" compression is proper but misfires. | Water in fuel system? | Flush fuel system and replace with correct type fuel. |
| | Ignition coil defective? | Replace ignition coil. |
| | Dirty spark plug? | Clean or replace spark plug. |
| Engine overheats. | Wrong fuel type? | Flush fuel system, and replace with correct type of fuel. |
| | Spark plug heat value improper? | Replace with correct type of spark plug. |
| | Cooling fins dirty? | Clean cooling fins. |
| Rotational speed fluctuates. | Governor adjusted correctly? | Adjust governor. |
| | Governor spring defective or missing? | Replace governor spring. |
| | Fuel flow restricted? | Check entire fuel system for leaks or clogs. |
| Recoil starter malfunction. | Recoil mechanism clogged with dust and dirt? | Clean recoil assembly with soap and water. |
| | Spiral spring loose? | Replace spiral spring. |



A DIVISION OF MULTIQUIP INC.

Terms and Conditions of Sale STOW Construction Equipment

PAYMENT TERMS

Terms of payment for unit sales are 2% 15 days net 30 days from date of invoice unless otherwise specifically stated on our invoice. Parts invoices have terms of net 10 days.

Minimum parts billing is \$15.00 net.

Applicable discounts will be computed on merchandise value only. Late charges will be assessed at prevailing rates. Cash discounts cannot be taken on current billings if any previously billed amounts are past due.

FREIGHT POLICY

Freight policy is established to offer customers every advantage possible. Due to bulk freight ratings on some equipment and other shipping considerations, freight policies differ by equipment type. Actual back freight may be charged for shipments originating from other than specified FOB warehouses. **See Freight Policy for details.**

All STOW domestic sales are FOB nearest available designated MQ/STOW warehouse. Export orders are ex-works factory located in Carson, CA or Boise, ID.

Additions to orders already shipped cannot be accepted for freight minimums.

Should STOW elect to make partial shipments of an order originally complying with the "freight allowed" requirements, transportation charges will be absorbed by STOW on any subsequent shipment applying to that order.

All other orders will be shipped collect or prepaid with charges added to the invoice. STOW's responsibility ceases when a signed manifest has been obtained from the carrier, and any claim for shortage or damage must be settled between the consignee and the carrier.

Parts: FOB Carson, California or Boise, Idaho. **See Freight Policy for details and additional discounts.**

DROP SHIPMENTS

STOW reserves the right to refuse Drop Shipments outside the normal service area of the purchasing dealer.

FIELD WAREHOUSES

Field Warehouses are currently located in California, Georgia, Idaho, Iowa, and New Jersey

SPECIAL EXPEDITING SERVICE

The higher of a \$35.00 surcharge or actual costs will be added to the invoice for special handling, including bus shipments, or in cases where STOW personnel must personally deliver the equipment or parts to the carrier.

RETURNED GOODS POLICY

Return shipments may be accepted and credit allowed, subject to the following provisions.

1. A Returned Material Authorization (RMA) must be approved by STOW prior to shipment. Approvals for returned goods must be with just cause and are at the sole discretion of STOW. A copy of the Authorization must accompany the shipment to the designated Warehouse.
2. Parts being returned must be listed as currently supplied on the current parts list.
3. Parts must be in new and resalable condition in the original package, with part numbers clearly marked.
4. Units and accessories must be current models in the latest price list and in new and resalable condition.
5. Special order items are not returnable for credit.
6. Credit on returned parts and units will be issued at actual dealer net price at time of purchase less 15% restocking charge.
7. All returned shipments are to be made to the STOW designated receiving point, freight prepaid at the sender's expense.

The sender will be notified of any material received that does not meet the above provisions. Such material will be held for 30 days from notification pending instructions. If a reply is not received within 30 days, the material will be returned to the sender at his expense with no credit issued.

PRICING, REBATES AND SPECIFICATIONS

Every effort will be made to provide adequate notice of changes; however, prices and equipment specifications are subject to change without notice.

Price changes are effective on a specific date and all orders received on or after that date will be billed at the revised price.

Rebates for price reductions and added charges for price increases will not be made for stock in dealer inventory at the time of a price change.

STOW reserves the right to quote and sell direct to Government agencies and to Original Equipment Manufacturer accounts who use our products as integral parts of their own products.

LIMITATION OF SELLER'S LIABILITY

STOW shall not be liable hereunder for damages in excess of the purchase price of the item with respect to which damages are claimed and in no event shall STOW be liable for loss of profit or good will or for any other special, consequential or incidental damages.

LIMITATION OF WARRANTIES

There are no warranties, express or implied, made by STOW hereunder on Products manufactured or distributed by it except the warranty against defects in material and workmanship on new Products to the original purchaser, as set forth in the STOW New Product Limited Warranty.

Effective: July 15, 2003



A DIVISION OF MULTIQUIP INC.

Atlanta • Boise • Newark • Quebec, Canada
Manchester, UK • Rio de Janeiro, BR • Puebla, MX

STOW CONSTRUCTION EQUIPMENT

POST OFFICE BOX 6254
CARSON, CALIFORNIA 90749
310-661-4242 • 877-BUY-STOW
FAX: 310-604-9237
E-MAIL: stow@stowmfg.com
www.stowmfg.com

OPERATION MANUAL

HERE'S HOW TO GET HELP

PLEASE HAVE THE MODEL AND SERIAL
NUMBER *ON-HAND* WHEN CALLING

PARTS DEPARTMENT

800-427-1244 FAX: 800-672-7877

310-537-3700 FAX: 310-637-3284

SERVICE DEPARTMENT

800-478-1244 FAX: 310-537-4259

310-537-3700

TECHNICAL ASSISTANCE

800-478-1244 FAX: 310-631-5032

WARRANTY DEPARTMENT

800-421-1244, EXT. 279 FAX: 310-537-1173

310-537-3700, EXT. 279

SALES DEPARTMENT

310-661-4242 FAX: 310-604-9237

877-289-7869 (877-BUY-STOW)

© COPYRIGHT 2007, MULTIQUIP INC.

Multiquip Inc, and the STOW logo are registered trademarks of Multiquip Inc. and may not be used, reproduced, or altered without written permission. All other trademarks are the property of their respective owners and used with permission.

This manual MUST accompany the equipment at all times. This manual is considered a permanent part of the equipment and should remain with the unit if resold.

The information and specifications included in this publication were in effect at the time of approval for printing. Illustrations, descriptions, references and technical data contained in this manual are for guidance only and may not be considered as binding. Multiquip Inc. reserves the right to discontinue or change specifications, design or the information published in this publication at any time without notice and without incurring any obligations.

Your Local Dealer is:

STOW

A DIVISION OF MULTIQUIP INC.
Atlanta • Boise • Newark • Quebec, Canada
Manchester, UK • Rio de Janeiro, BR • Puebla, MX

MQ STOW CONSTRUCTION EQUIPMENT

A DIVISION OF MULTIQUIP INC.

POST OFFICE BOX 6254

CARSON, CA 90749

310-537-3700 • 888-252-MQ STOW [888-252-7869]

FAX: 310-537-1986 • FAX: 800-556-1986

E-MAIL: MQ STOW@multiquip.com • WWW: stowmfg.com